

**IBOC TECHNOLOGY:
An Assessment of Technical & Operational Issues
in the Canadian FM Radio Environment**

**Prepared by
the
Digital Radio Co-ordinating Group**

24 May 2007

Report Summary

The Digital Radio Co-ordinating Group (DRCG) has prepared this report to assist broadcasters and government regulators in assessing the technical & operational issues associated with introducing in-band on-channel (IBOC) digital radio broadcasting (DRB) services in the Canadian FM radio environment. Because it has been adopted as an IBOC standard by the US FM radio industry, and equipment was therefore readily available, iBiquity Digital Corporation's HD Radio™ system was utilized in this evaluation.

The DRCG's work has been made possible largely through the co-operation of the CBC, which had been intending to undertake such studies in roughly the same time-frame. The DRCG assumed a co-ordinating role among the CBC, the CRC, the private broadcasters and Industry Canada, to ensure that the data that was generated would serve the information needs of all interested parties. Other sources of information, including that generated during intensive US IBOC testing conducted by the National Radio Systems Committee (NRSC) and National Public Radio (NPR), were examined and compared with the results obtained in Canada.

The technical evaluations involved lab tests in Montreal by the CBC and in Ottawa by the CRC. The latter work is on-going and is expected to produce additional information before the end of 2007. However, the principal source of information was from field testing performed by the CBC and the CRC in Toronto and the Niagara region. The field implementation primarily involved the use of two CBC transmitters, CBL-FM and CJBC-FM, which enabled testing of HD Radio in both its single simulcast (HD1) and multicast (HD2/3) modes.

The four key issues requiring examination in this study were:

- the principal differences between the US and Canadian FM operating environments;
- the impact of the HD Radio digital signal on the analog service of the host FM station;
- the ability of the HD Radio digital service to duplicate the protected analog service area of the host FM station; and,
- the extent to which HD Radio signals may cause interference to analog and digital stations operating on adjacent channels.

The iBiquity HD Radio system for the FM band is tailored rather precisely to the operating environment found in the United States, where interference-free service for many US stations is achieved only within their 1 mV/m (60 dB μ V/m) contours. Outside this area, any lack of digital service from host stations, or interference to analog services from adjacent-channel IBOC operations, would be considered acceptable. In Canada, FM service is generally protected within each station's 0.5 mV/m (54 dB μ V/m) contour, which is substantially larger in area. Moreover, it is not common practice in the US to assign regular FM stations within 800 kHz of each other in the same area, whereas in Canada same-market assignments as close as 600 kHz are permitted. This effort to achieve additional FM allotments in areas of high demand will constrain the ability of local stations to add new in-band digital carriers because many of the new 3rd-adjacent drop-ins operate at low parameters.

The lab and field investigations conducted by the CBC suggest that most stations would be able to implement HD Radio within their protected service areas without producing an unacceptable impact on the quality of the host analog FM service. Providing a digital version of the analog programming would be particularly beneficial in areas where the FM signal is prone to multipath distortion.

With respect to coverage duplication, the CBC field work revealed that reliable digital service to vehicles is generally possible for the main simulcast (HD1) service when receivers are located inside the analog station's 1 mV/m service contour. Beyond this, receivers will much more frequently blend back to the analog signal, so as not to lose the program altogether. For multicast programming services (HD2/3), the analog station's 3 mV/m contour (69.5 dB μ V/m), may be considered an appropriate planning limit for reliable digital service. This is principally because these additional programs have no simulcast analog fall-back.

While neither the lab nor field tests suggest interference problems for 2nd-adjacent stations (400 kHz dial separation), this is not the case with stations that are on 1st-adjacent channels (200 kHz dial separation). Due to band congestion in Canada, there are now many cases where 1st-adjacent stations are situated as close together as the analog spacing rules permit. The lab and field investigations conducted to date indicate that, in such instances, a station that has incorporated HD Radio can produce a significant area of interference within the 0.5 mV/m protected analog service contour of a 1st-adjacent neighbouring station.

These test results produce three important conclusions with respect to the potential impact of any wide-scale implementation of HD Radio in the FM band in Canada:

- Since the analog blending feature allows HD1 programs to tolerate a higher degree of digital signal failure, the 1 mV/m FM contour may be considered a reasonable coverage limit for simulcast (HD1) services, especially to vehicular receivers.
- Broadcasters introducing multicast (HD2/3) programs, that have no analog fall-back and therefore require higher reliability, should not anticipate achieving service much beyond their 3 mV/m analog service contours.
- Analog audiences located between each station's 0.5 mV/m and 1 mV/m contours would be at risk of experiencing increased interference when 1st-adjacent stations in abutting markets introduce HD Radio services;

The issue of reliable indoor reception of HD Radio signals still needs to be fully investigated. Early evidence suggests that the very low digital-to-analog power ratio (1:100) that must be employed would make it difficult to achieve reliable indoor digital reception, especially with table and portable receivers that are attempting to receive multicast HD2/3 programs that have no analog fall-back.

Based on the evidence currently in hand, the DRCG considers that it would be risky for Canadian broadcasters to proceed at this time with an unrestricted roll-out of HD Radio services in the FM band, in the manner implemented in the US. There is no ground-swell of radio listener interest in this technology so far and the lack of inexpensive receivers, as well as unique new programming services, continues to make it difficult to market HD Radio to the public in the US.

Moreover, there is no evidence that Canadian digital radio listeners are being lost to the 10% of US FM stations that have implemented HD Radio to date.

Considering all of the evidence presented in this report, the DRCG makes the following recommendations with respect to the Canadian FM-band environment:

- (1) As announced in its revised radio policy, the CRTC should refrain from licensing permanent HD Radio or other in-band DRB operations until Industry Canada has established appropriate technical rules.**
- (2) Before regulatory action is taken to authorize permanent in-band DRB facilities, Industry Canada should:**
 - complete a detailed technical evaluation of in-band technologies, including theoretical studies by CRC as well as additional co-operative field assessments in spectrum-congested markets; and,**
 - establish clear mitigation measures to deal with harmful interference, if caused by digital operations within the protected service areas of existing stations.**
- (3) Broadcasters should continue monitoring in-band DRB developments, especially in the USA, to determine when it may be appropriate to introduce this technology in Canada, taking into account the following indicators:**
 - the number of affordable portable and home in-band DRB receivers that are being purchased by the public; and**
 - the number of in-band DRB receivers that are being purchased as OEM equipment in new vehicles in North America; and**
 - the tuning levels for in-band DRB services (both simulcast and multicast) that are being achieved in US radio markets.**

Table of Contents

	Page #
Report Summary	
1. Introduction	1
2. Hybrid HD Radio FM-Band Technology	4
3. Comparison of HD Radio and Eureka Technologies	6
4. Comparison of the Canadian and US FM Band Operating Environments	8
5. HD Radio Assessments	11
6. Coverage Duplication Issues	12
7. Host Compatibility Issues	14
8. Adjacent-Channel Interference Issues	15
9. Practical HD Radio Implementation Considerations	18
10. Related Regulatory and Other Issues	19
11. Conclusions and Recommendations	21
Appendix 1: List of CBC Report References	
Appendix 2: IBOC Implementation Issues	
Appendix 3: DRCG Members - 2007	

1. Introduction

The Digital Radio Co-ordinating Group (DRCG) has prepared this report in order to provide Canada's broadcasters and regulators with objective advice on the technical and implementation issues associated with In-Band On-Channel (IBOC) digital radio broadcasting (DRB) in the FM band (88-108 MHz).

The DRCG was created in the early 1990s, when broadcaster interest in digital radio was first stimulated by exciting new technology developments in Europe. The group's purpose is to carry out investigative projects and research, providing decision-makers in industry and government with the technical information they require to plan future digital radio broadcasting (DRB) services. Members are drawn from the ranks of senior engineering personnel employed by private broadcasting companies, the CAB, the CBC, the Communications Research Centre (CRC), private engineering consulting firms, Industry Canada and the CRTC.¹ While it functions in the manner of a joint government/industry consultative committee, the DRCG does not operate under the auspices of any specific government department or industry organization. Moreover, while representatives of government departments and agencies sit on this committee, their primary role is to provide advice and consultation on technical issues of common interest. It should not be inferred that positions or recommendations adopted by the DRCG necessarily have prior agreement and consent from these departments and agencies.

At WARC-92², Canada was a strong proponent of allocating new spectrum for DRB. The conference decided that 40 MHz of L-Band spectrum (1452-1492 MHz) would be allocated on a primary, world-wide basis for this purpose. Some countries that had not been using this spectrum extensively for other purposes (e.g. Canada & France) proceeded to plan for new L-Band DRB services fairly quickly thereafter. Other countries (e.g. the UK and Germany) accepted the allocation of the new band for DRB but did not licence any services for many years, allowing time for existing non-broadcast users to vacate the spectrum. The USA opted, via an allocation footnote, not to utilize this band for broadcasting services at all.

In 1995, Industry Canada created a national channel allotment plan for L-Band DRB, based on the use of the Eureka 147/DAB transmission standard, and the CRTC issued a "transitional" licensing framework.³ This policy generally allowed each existing AM and FM licensee to apply to simulcast its analog programming service, using up to one-fifth of the multiplex capacity of an L-Band DRB channel allotted to the community of licence. Up to five local radio services could therefore share a DRB transmitter, allowing lower implementation costs for each broadcaster in the multiplex. Since 1998, 76 DRB undertakings have been licensed in five Canadian radio markets and approximately 51 are in operation.

¹ See Appendix 3 for the current roster of members.

² The 1992 ITU-R World Administrative Radio Conference, at which many radio spectrum bands were reviewed and re-allocated.

³ Ref: Public Notice CRTC 1995-184; "A Policy To Govern the Introduction Of Digital Radio".

In its 2006 Radio Policy Review, the CRTC outlined a number of reasons why the implementation of L-Band DRB has stalled in Canada.⁴ Chief among these is the limited availability and high cost of receivers. Coupled with this is a lack of contiguous DRB coverage between major urban centres, which has meant that the North American automobile industry has so far supported digital satellite radio subscription services rather than free local terrestrial DRB services. The Commission also noted that a surge in DRB popularity enjoyed in other countries, especially the UK, may be attributable to the fact that their stations often provide unique programming, available only on DRB platforms. It also suggests that subscription satellite radio and audio streaming on the internet are being used increasingly by Canadians to acquire a greater variety in radio programming and that this may be affecting consumers' interest in DRB.

Finally, the CRTC Public Notice comments on the decision by the FCC not to provide a new band for local, terrestrial DRB services in the USA. Instead, US broadcasters have been encouraged to develop technologies enabling the implementation of digital services within the existing AM and FM bands. The CRTC suggests that this may have precluded certain economies of scale in the provision of DRB receivers in Canada, which might have occurred had the US agreed to domestic use of the world-wide L-Band DRB allocation.

In a recent announcement, the FCC authorized permanent, non-mandatory hybrid IBOC DRB transmissions by US broadcasters⁵ The AM-band and FM-band IBOC systems adopted by the US radio industry are described in a set of technical standards, prepared by the National Radio Systems Committee (NRSC), based on technology developed by iBiquity Digital Corporation.⁶ This system is being marketed under the trade name "HD Radio™". As of mid-April 2007, about 946 US FM-band IBOC stations (10.3% of total) and 185 AM-band⁷ stations (3.9% of total) had been authorized by the FCC under Special Temporary Authorizations⁸.

The DRCG decided to prepare this report because Canadian FM broadcasters need to know whether IBOC DRB might be used, either on a stand-alone basis or in conjunction with L-Band Eureka-147/DAB (Eureka) services, as part of a long-term strategy to transition their industry to an all-digital environment. Since iBiquity's HD Radio IBOC technology is being used extensively in the US, and is being considered for use elsewhere in the world, this was the system chosen for the present Canadian evaluation.

⁴ Ref: Broadcasting Public Notice CRTC 2006-160, 15 December 2006; paras 3-8

⁵ Ref: "Second Report and Order, First Order on Reconsideration, and Second Further Notice of Proposed Rulemaking" (FCC 07-33; 2007-03-22; MB Docket No. 99-325). The US IBOC DRB model is described as a "hybrid" because each station transmits its digital information using some (or all) of the transmission facilities employed by its analog AM or FM service.

⁶ See "NRSC-5-A ;In-band/on-channel Digital Radio Broadcasting Standard"; National Radio Systems Committee; September, 2005

⁷ Under the interim authorizations, AM-band IBOC transmissions in the USA were restricted to 6am-6pm local time, due to night-time skywave interference concerns. In Decision FCC 07-33, this restriction was lifted.

⁸ Source: FCC Apr 2007; DRB STA are listed at <http://www.fcc.gov/mb/audio/digital/index.html>. Total US radio station counts are listed at <http://www.fcc.gov/mb/audio/totals/bt061231.html>

The DRCG's project has been made possible largely through the co-operation of the CBC, which had been intending to undertake such studies in roughly the same time-frame. The DRCG assumed a co-ordinating role among the CBC, the CRC, private broadcasters and Industry Canada, to ensure that the data that was generated would serve the information needs of all interested parties. This report blends Canadian information with data collected from other reports and studies, for the most part conducted in the US.

The fact that these evaluations are underway in Canada at this time is especially significant in light of the CRTC's 2006 digital radio policy revision announcement. In its Public Notice, the Commission indicates that it would be prepared to license IBOC DRB in both the AM and FM bands in Canada, provided that certain technical issues can first be resolved.⁹ Among these are:

- possible degradation of the "host" analog services by the digital hybrid signals;
- IBOC's ability to replicate analog service areas; and
- potential IBOC interference to other stations, both digital and analog.

The Commission has indicated that it is willing to set up a licensing frame-work for IBOC once these technical issues are examined, the results are known and Industry Canada has adopted suitable transmission standards. The CRTC's decision states that it is prepared to give consideration to in-band DRB services employing either the iBiquity HD Radio system or competing Digital Radio Mondiale (DRM) technology.¹⁰

It is expected that the present study will assist broadcasters and regulators in dealing with the technical questions mentioned above. This report outlines the results of the DRCG's investigation only with respect to the FM-band hybrid version of HD Radio. Future studies are planned for the AM-band hybrid version (and possibly DRM).

The DRCG's technical investigative work was carried out by employing field observations as well as lab and theoretical analyses. Field observations involved both objective measurements using test vans and subjective observations using passenger vehicles equipped with HD Radio receivers. Planning for the tests was conducted by an ad-hoc DRCG subcommittee. Equipment was provided by the CBC, Industry Canada, the CRC and Digital Radio Roll-out Inc (DRRI). Field and lab work was undertaken primarily by CBC Technology engineering staff; however, CRC personnel also conducted a limited field assessment, primarily to validate coverage and interference prediction techniques.

Additional theoretical analyses of analog/digital coverage duplication and interference are being undertaken by CRC staff, using its CRC-COVLABTM software, modified for this

⁹ Ref: Broadcasting Public Notice CRTC 2006-160; paras 55-57

¹⁰ DRM is an open-standard digital system that enables analog services operating in the short-wave and medium-wave (AM) bands to convert to digital transmission. Occupying the same bandwidth as conventional AM broadcasts, DRM is intended as a direct replacement for analog services and does not accommodate hybrid analog/digital transmissions simultaneously on the same channel.

specific purpose. These studies are expected to be completed by Fall 2007 and will be made available to the industry at that time.

FM-band HD Radio test transmissions took place in Toronto from August – December 2006, using the First Canadian Place facilities of CBLA-FM (99.1 MHz) and CJBC-FM (90.3 MHz). Transmissions over a shorter time-frame were also conducted using the facilities of CBCP-FM Peterborough (98.7 MHz); however, technical difficulties at this site meant that some of the tests to assess the impact of second-adjacent IBOC interference from nearby transmitters could not be completed.

The CBC's engineering report on laboratory and field testing, as well as its technology trial report, may be obtained at the FTP sites referenced in Appendix 1.

2. Hybrid HD Radio FM-Band Technology

When an FM station implements HD Radio in the hybrid mode, digital programming is provided using 384 very low-level radio carriers that are split equally into two sections and placed just above and just below the spectrum utilized for the transmission of that station's analog signal. This puts these digital signals within the analog radio channel used by stations operating on 1st-adjacent frequencies. For example the HD Radio carriers of a station licensed for 99.1 MHz would sit within the analog channel of stations operating on 99.3 MHz and 98.9 MHz.

While HD Radio is referred to as an “in-band, on-channel” system, this is not an entirely accurate description of what actually happens. The digital signals are indeed “in-band” (i.e. in the FM band). However, they are not really “on-channel”, since their primary energy is transmitted in channels that are immediately above and below the channel on which the analog signal is being transmitted. The main element of commonality between the analog and digital emissions for any given HD Radio station is that they are transmitted from exactly the same site, usually via the same antenna but not always using the same transmitter.

There are two key theoretical reasons why such a system can work: the first is that stations on 1st-adjacent channels cannot be assigned to the same market; therefore, their protected analog service areas should not overlap. Secondly, the digital carriers emitted on adjacent channels are set to such a low power level that, in theory at least, they should not cause interference to analog receivers tuned to stations operating on these frequencies. On the other hand, HD Radio digital receivers will ignore the adjacent analog FM signals and decode only the desired digital signals. Later sections of this report describe how all this actually works in the real world.

The digital signal transmitted by an HD Radio station has a reliable data capability of about 96 kbits/sec. As with Eureka, this available data stream can be carved up so that multiple programs can be broadcast using the same transmitter. Most HD Radio broadcasters would probably want to use the predominant portion of this capacity, say

64 kbits/sec, to provide stereophonic digital versions of their analog programming. This is generally referred to as the “HD1” signal. The remainder of the data stream (32 kbits/sec) can then be used for a second “multicast” program service (HD2). Alternatively, two additional programs (HD2 and HD3) with 16 kbits/sec each might be provided.

HD Radio receivers are designed so that they can be instructed by users to revert automatically to the main analog audio service upon failure of the digital signal. This feature, called “blending”, can only be invoked when the HD1 and analog programming content are absolutely identical. The switching occurs seamlessly and without intervention by the listener if the receiver’s blending function has been activated. The principal impact of blending is that the main audio reverts to “FM-quality” and the signal once more becomes prone to FM analog artifacts, such as multipath distortion. Nevertheless, the listener does not lose the program. When the digital signal returns, the receiver switches back automatically to the superior digital signal.

For a variety of reasons relating to the time requirements for digital signal processing, it takes 8-10 seconds for the digital audio signals to be heard when an HD Radio receiver is first tuned to a transmission. Likewise, it can take equally long to restore digital quality when the signal fails and then returns again. A secondary consequence of this processing delay is that programming fed to the analog FM transmitter must be delayed by 8-10 seconds whenever the blending feature is being utilized. This ensures that content is not lost when the receiver switches back to analog mode during a digital signal failure. Stations using this technology may need to implement certain internal operational changes to accommodate the fact that off-air listeners will experience delays of up to 10 seconds with both the analog and digital versions of their programming.

Since no analog program version exists for ancillary HD2 or HD3 programming, listeners experiencing digital failures must simply tolerate audio outages until the signal restores itself. While there is no technical reason why the HD1 content cannot be different from the main FM audio service, doing this would mean that it would suffer the same outage as the HD2/HD3 programs experience under signal failure conditions.

A unique aspect of HD Radio is the fact that an important element of this technology remains proprietary to iBiquity. Most broadcast transmission standards in use today have been patented by someone. The rights-holders are paid royalties whenever equipment employing the standard is sold: these costs are simply built into the selling prices determined by the manufacturers. Such technologies are characterized in so-called “fully-described, open standard” documents, often issued by international bodies such as the ITU-R. Anyone is free to build equipment using these standards, so long as the appropriate royalties are paid under a compulsory licensing scheme. This system allows technical improvements to be made over time, through system enhancements developed by the original inventor or by others.

HD Radio’s technology is described in the NRSC-5-A standard document (see footnote 6). While NRSC-5-A may be an “open” standard, it is not “fully-described”, in that the internal workings of its audio coding and encoding system (codec) have not been divulged

by iBiquity.¹¹ As a consequence, iBiquity remains a “gate-keeper” with respect to who may produce products bearing the “HD Radio” label, as well as with respect to any future enhancements to the system. Time will tell whether this departure from the norm with respect to broadcasting standards will make it more complicated for regulators in different countries to adopt HD Radio as a digital standard, voluntary or otherwise.

3. Comparison of HD Radio and Eureka Technologies

Many Canadian broadcasters already have knowledge of, and experience with, the Eureka system that has been implemented in this country using L-band frequencies. In this section, the principal differences between the Eureka system and the FM-band version of HD Radio are outlined, so that the capabilities of the latter technology can be compared with its more well-known counterpart.

- **Data capacity per transmitter:** HD Radio is intended for implementation in the existing VHF FM band and needs to comply with the 200 kHz channel spacing scheme utilized for analog frequency allotments. This bandwidth limitation means that the maximum effective audio data payload (after error correction) for the digital signal carried on each transmitter is about 96 kbits/sec. The wider channel bandwidth used for L-Band Eureka transmission permits a comparable audio data throughput per transmitter of about 1152 kbits/sec.
- **Audio Programs per transmitter:** In most cases, up to three (HD1/HD2/HD3) separate digital audio programs can be accommodated within the data capacity transmitted by HD Radio. Using the current standard MPEG-2 audio coding scheme, Eureka can generally deliver a minimum of 5 stereophonic audio programs; however, in some countries (e.g. the UK), as many as 10-11 programs of lower quality are being delivered. The Eureka standard has recently been modified to permit the use of DAB+TM audio coding, which should permit 15-20 high-quality audio programs to be carried on each digital transmitter.¹²
- **Audio Quality:** Proponents of both HD Radio and Eureka claim that the audio delivered by their system is “CD-quality” (which is not actually defined). In fact, for both systems, audio quality is a trade-off against the number of individual programs delivered by a given transmitter and whether these are stereophonic or monophonic. Each system can be viewed simply as a “digital pipeline” through which a finite number of data bits can be delivered to listeners. How this data stream is shared by all the audio programs that must be carried is generally left to individual operators to decide.

¹¹ HD Radio’s spectrum emission mask and OFDM parameters can be found in ITU-R document BS. 1114-2; however, the information bit-stream and codecs are proprietary to iBiquity.

¹² Legacy receivers will not decode audio that has been processed using DAB+; however, receivers that will be available later in 2007 will decode both the old and new standards.

- **Ancillary Services:** Both the HD Radio and Eureka systems have the ability to deliver program-associated data (PAD), such as text streams containing the name of the station, the program name, artists' names, etc. Due to its much higher data capacity, the Eureka system can also carry other ancillary services, such as Digital Multimedia Broadcasting (DMB) or Internet Protocol (IP) data.
- **Multipath Immunity:** Both HD Radio and Eureka utilize a transmission method known as Orthogonal Frequency Division Multiplexing (OFDM), where the digital data is spread over many carriers. As a result, both systems are largely immune to the multipath problems that plague FM analog transmissions. Because of its wider bandwidth, the Eureka system benefits more from OFDM than does HD Radio.
- **Transmitter Configurations:** HD Radio transmissions must originate from the same site as the FM transmissions to which they are related. Typical equipment requirements are discussed in Section 9 and Appendix 2 of this report. Each FM broadcaster requires its own HD Radio transmission facilities; however, just as in FM, several broadcasters may be able to share a common antenna. Since Eureka operates in a separate band, each installation requires its own transmitter, which is shared by all program services licensed for that multiplex. As with the FM band, L-Band antennas can be shared when appropriate. It is not necessary to co-locate analog and digital facilities when Eureka transmissions are utilized, so there is more flexibility in siting. L-Band antennas are also much smaller than those used in the FM band, making it possible to utilize less robust supporting structures.
- **Permissible Power:** In order to minimize interference to the host FM station and frequency-related neighbouring stations, hybrid HD Radio signals must be limited to 1/100th the power transmitted by the analog FM station with which they are associated. While this allows a 100 kW FM station to emit an HD Radio power of 1 kW, smaller FM operations (e.g. Class A stations) may only be radiating 30-60 watts of digital power, which affects their ability to penetrate buildings and overcome signal path obstructions. In areas subject to the Canada-US agreement on L-Band, the maximum power limit for the Eureka system is 50 kW ; however, it is very expensive to generate such high power in this band and most facilities operate at a much more modest level. A considerable advantage of the Eureka system is that it can utilize on-channel repeaters. This enables broadcasters to avoid using high-powered individual transmitters and instead to construct a network of interconnected smaller transmitters that can produce signal levels throughout the coverage area that are strong enough to overcome the higher building attenuation and other obstruction losses prevalent at L-Band.
- **Outdoor Coverage:** The area within which reliable coverage of a typical hybrid HD Radio transmitter is possible is detailed in Section 6 of this report. As a rule of thumb, it can be assumed that the realistic outdoor reception limit for digital service to mobile receivers will extend to a point somewhere between the official 3 mV/m (69.5 dB μ V/m) and 1 mV/m (60 dB μ V/m) contour of the related analog FM station, depending upon local conditions. Work is being carried out in the US to investigate

possible back-filling of HD Radio coverage gaps with on-channel digital repeaters; however, the outcome of this is still uncertain because of the increased potential for interference to analog services. The reliable coverage of Eureka L-Band transmitters is primarily determined by antenna height, transmitter power and the roughness of the local terrain. Due to the higher frequencies, signal attenuation as a function of distance is much greater at L-Band than in the FM band. Unless high antennas are used and the local terrain is quite flat, the coverage of individual L-Band transmitters will seldom exceed 30-40 km. On the other hand, Eureka's coverage range and reliability can be extended almost indefinitely through the use of on-channel coverage extenders and gap-filler transmitters. Of course, this requires multiple transmitter sites, adding both capital and operating costs.

- **Indoor Coverage:** All digital transmission systems experience more difficulties than analog systems when indoor reception is attempted. Whereas analog FM reception may simply become noisy (hissy) when building walls attenuate the signals, digital services can fail altogether. With respect to the reception of HD Radio indoors, the CBC did not evaluate this with specific tests; however, the Corporation's engineering assessment report states:

*“Some limited indoor assessment has demonstrated that HD Radio is very difficult to receive in an indoor environment. Consequently, it should be expected that any HD2 services would not be received in indoor conditions with the current generation of receivers.”*¹³

Canadian experience with L-Band Eureka receivers operating indoors has also been spotty. Due to the shorter wavelengths, L-Band signals experience even greater through-the-wall signal attenuation than do FM and HD Radio signals. On the other hand, where even small windows and other openings exist, the shorter-wavelength signals are much better able to creep inside. Whereas table-top L-Band receivers and tuners are able to function reasonably well under indoor reception conditions, smaller personal portable DRB receivers often must be carefully situated. It should also be noted that on-channel repeaters common in Eureka transmissions provide space-diversity that considerably enhances indoor reception.

4. Comparison of the Canadian and US FM Band Operating Environments

HD Radio was designed to fit as seamlessly as possible within the FM analog broadcasting environment that currently exists in the USA. As such, its designers considered only the domestic frequency assignment and service protection scheme that currently exists for the US FM band. They did not take into account different domestic and service protection requirements that might exist elsewhere in the world or the protection requirements called up under bilateral agreements with Canada and Mexico.

¹³ Ref: “*IBOC Field and Lab Trial Results from Toronto, ON*”, CBC Report ER-0605; at page 23 (see Appendix 1 of this report.)

In many respects, the operating environment for Canadian FM stations is very similar - sometimes even identical - to that of their US counterparts. However, there are some significant differences between the regulatory and service approaches that have been taken over the years by each country. This section of the report discusses these differences and how the potential impact of implementing HD Radio in Canada might vary from that being experienced in the US.

Frequency Allotment Principles

The FCC's frequency allotment rules ensure that a station that is separated by only 3 channels on the dial (i.e. 600 kHz) from a local station cannot be sited within the protected contour of the latter station. In an effort to increase the number of FM allotments available in congested areas, Industry Canada determined in 2002 that it would allow 3rd-adjacent stations to be located within the same market. New stations approved under this rule often operate at power levels that are considerably below those of the related incumbent stations. Whereas the existing station may operate at 100 kW, the incoming 3rd-adjacent station can often only be licensed at a much reduced power level and therefore can experience a certain degree of overloading interference from its more powerful neighbour. The converse situation usually does not arise, since the incumbent station's power is much higher than that of the newcomer.

Should the weaker station in the above scenario attempt to implement HD Radio, where the digital signal is only 1/100th the power of the analog signal to begin with, overloading may be compounded to the point where digital service is not feasible. This is an issue that is not likely to arise in the US; however, it may make it impossible for some Canadian 3rd-adjacent stations to implement HD Radio services.

Protected Coverage Limits

Many commercial US FM stations, which operate in the frequency range from 92.1 MHz to 107.9 MHz¹⁴, receive interference protection only to their 1 mV/m (60 dB μ V/m) contours. In Canada, all stations receive protection against interference at their 0.5 mV/m (54 dB μ V/m) contours. To place this in perspective, Table 1 describes the typical radial distances and service areas associated with these contour levels, by station class.

Since the majority of analog FM stations in the US are commercial, it was logical that the HD Radio system should be designed to ensure protection for existing analog stations to the same limit. As a result, wherever coverage exists outside a station's 1 mV/m contour,

¹⁴ As band segmentation no longer exists in Canada, both commercial and non-commercial stations may operate on any valid frequency within the entire FM band (88.1 MHz – 107.9 MHz).

there is a potential for new interference from a frequency-related station that has implemented HD Radio.¹⁵

Table 1

Station Class	1 mV/m Contour		0.5 mV/m Contour	
	Radius (km)	Area (sq-km)	Radius (km)	Area (sq-km)
A1	13	531	18	1,017
A	28	2,463	38	4,536
B1	38	4,536	51	8,171
B	51	8,171	65	13,273
C1	72	16,286	86	23,235
C	83	21,642	97	29,559

In the Canadian context, this risk would exist for virtually all stations that have not already accepted analog interference limitations within their 0.5 mV/m contours.

Permissible Interference Levels

The technical rules governing how much co-channel and 1st-adjacent interference analog FM broadcasters are obliged to accept at their protected contours are identical for both Canada and the US. Only on 2nd- adjacent channels is the Canadian domestic rule different. Table 2 compares the requirements in both countries.

Table 2.

Channel Relationship	Perm. interfering signal field strength (as fraction of desired signal)
Co-Channel (Canada & US)	1/10
1 st -Adjacent (Canada & US)	1/2
2 nd -Adjacent (Canada)	20/1
2 nd -Adjacent (US)	100/1

¹⁵ The potential impact of interference from HD Radio within the area between the 2 mV/m and 0.3 mV/m contours of US public radio stations is currently the subject (inter-alia) of a technical study commissioned by the Corporation for Public Broadcasting (CPB).

The 2nd-adjacent frequency relationship is not a critical issue when considering interference to analog FM services from HD Radio, so the difference between the Canadian and US rules is inconsequential. The same models of FM analog receivers are used in both countries and therefore have identical performance characteristics with respect to co-channel and 1st-adjacent channel interference. Consequently, it can be concluded that the same criteria may be applied in both countries when assessing whether harmful interference from HD Radio is occurring within a specific protected analog contour.

5. HD Radio Assessments

Audio Performance

Assessment of the general quality of the audio received by HD Radio receivers was not part of the field and lab studies conducted by the DRCG. However, a substantial amount of work on this issue was conducted by the NRSC prior to making its recommendation to the FCC to adopt the HD Radio standard. iBiquity stressed throughout its technology development process that the objective was to produce an in-band DRB system that provides listeners with enhanced audio, often referred to as “CD quality”. This term is subjective; however, it is generally understood to mean stereophonic audio having an extended frequency response, low noise and very low distortion.

In this regard, the NRSC’s Evaluation Working Group reported as follows:

“We believe these findings are consistent with the conclusions and recommendations in the NRSC’s ‘Evaluation of the iBiquity Digital Corporation IBOC System, Parts 1 and 2’ (FM IBOC – November 29, 2001; AM IBOC – April 6, 2002), and conclude that the Gen 3¹⁶ systems satisfy the original “Goals and Objectives” of the DAB Subcommittee by providing a digital signal with significantly improved audio quality over AM and FM analog systems that presently exist in the United States.”¹⁷

Observations made throughout the testing conducted in Canada support the conclusion that the audio quality of the HD Radio signal is at least as good as that of the FM analog host station. Indeed, some observers subjectively judge it superior to FM when the entire available data capacity of 96 kbits/sec is being utilized to simulcast the main programming.

Multipath Performance

Because HD Radio makes use of multiple digital carriers, which are duplicated at the top and bottom ends of the radiofrequency channel, its ability to resist multipath distortion is much superior to that of FM analog. In fact, one of the key benefits of implementing HD Radio in major metropolitan areas would be its ability to correct for multipath reflections from buildings and other infrastructure, as well as terrain.

¹⁶ i.e. the current HD Radio audio codec system, HDC™

¹⁷ NRSC Evaluation Working Group memo; 2004-06-30; at page 7

In its test report, the CBC shows the results of lab tests conducted with a “channel simulator” that adds signal distortions typical of urban multipath environments. Subjective evaluations of HD Radio’s multipath resistance were also made during the field tests in Toronto. The report’s conclusions state:

“In the course of this trial, the main upside that was found about HD Radio is that it has the potential to drastically reduce the multipath reception problems due to the many high-rise buildings of downtown areas, such as Toronto. Especially for a stereo station, such as CJBC-FM, this has the impact of going from a fair listening experience to a good or very good listening experience in many areas of the downtown core.”¹⁸

Multiplex Trade-offs: Quantity vs. Quality

Section 2 of this report describes the digital data capabilities of HD Radio. Broadcasters implementing this technology basically have a 96 kbits/sec “digital pipe” at their disposal. Some may decide to use the entire capacity to simulcast their analog stereophonic programming (HD1) at the highest possible quality. Others may choose to reduce the data rate for their HD1 simulcasts and utilize the liberated data capacity for other audio programming or ancillary data purposes. The price for doing this is reduced audio quality for the HD1 service, possibly to the point where it may be more akin to “FM-quality” than “CD-quality”.

The offsetting benefit is that one or two additional, separate audio programs can then be carried. Each of these will be of lesser quality than the HD1 service and will also be subject to abrupt outages wherever the HD Radio digital signals fail. The HD1 simulcast audio, on the other hand, will continue to be heard because receivers will revert to analog FM reception at the digital failure point. Whether HD2/3 services are stereophonic or monophonic will depend on the fraction of the overall 96 kbits/sec data availability assigned to them.

6. Coverage Duplication Issues

Most broadcasters implementing HD Radio would want listeners to be able to enjoy higher-quality digital services anywhere within their licensed analog coverage areas. However, exactly duplicating analog service areas with any type of digital radio transmission is generally not possible. The nature of analog radio is such that signals tend to fade, gracefully or otherwise, until they reach a point where they are so noisy that listeners simply turn off their radios or tune to another station. The sound is still there but no one wants to listen to it because the audio quality is unacceptable.

Digital radio, on the other hand, retains its original audio quality until the signal is so weak that it can no longer be decoded. Near the failure point, receivers sometimes produce burbling or squawking audio for a few seconds and then the program disappears completely, as the receiver mutes to prevent further listener annoyance. This is sometimes

¹⁸ Ref: CBC Report ER-0605; at page 25

called the “cliff effect” and it can occur in all types of digital radiocommunication transmission, including TV, satellite and wireless telephony.

As noted in Section 4, the HD Radio system was designed for the US FM radio environment, which often ensures reliable analog service only to the 1 mV/m contour. This is called the “protected contour”, since beyond this, FM signals are not protected against interference from other analog stations. Canada’s FM stations are generally protected to the 0.5 mV/m contour, which falls further away from the transmitter site. This recognizes the more geographically disperse nature of radio audiences in Canada, as well as the fact that urban agglomerations are often more widely spaced. Table 1 in Section 4 gives typical coverage radii and areas for FM radio’s 1 mV/m and 0.5 mV/m contours, according to station class.

While it is often possible under favourable conditions to receive both analog and digital signals outside protected contours, broadcasters have no assurance that this can continue indefinitely. Normal growth in stations in near-by markets will often erode service that may have been available previously in non-protected areas. Usually this is manifested by increasing levels of co-channel and/or adjacent-channel interference.

Evaluations carried out in the US by National Public Radio (NPR) have demonstrated that reliable HD Radio service outside the 1 mV/m analog contour should not be expected. This can be seen in the results of field surveys conducted in four large US radio markets, as part of NPR’s “*Tomorrow Radio*” field testing project. The Tomorrow Radio project involved splitting the HD Radio digital channel into two separate audio programs (HD1 & HD2) and determining where these services can be received reliably, in relation to the analog service areas of the stations concerned. The NPR report on these tests states:

*... we conclude that, with 95% certainty, the Tomorrow Radio usable service area would fall within a given station’s 60 to 70 dBu service area.”*¹⁹

The CBC field studies in Toronto produced similar results. The Corporation’s report states:

*“On the downside, it was identified that the total digital coverage will be smaller than the existing analog coverage. This has less impact for an HD1 simulcast service, as there is fallback of the HD Radio to the analog when the digital signal is lost. For instance, for CBLA-FM, this means a reduction of coverage from around 80 km to around 65 km in radius (58 km to 45 km for CJBC-FM – see HD Radio Blending Contour on executive map F-7209). But for future HD2 services, it is of greater concern as this means a major reduction in service area (80 km to 50 km for CBLA-FM and 58 km to 32 km for CJBC-FM – see HD Radio “Digital Only” Contour on executive map F-7209).”*²⁰

The referenced Figure F-7209 identifies the (HD1) blending contour as falling approximately in the same location as the analog FM station’s 1 mV/m contour, whereas

¹⁹ Ref: “*Tomorrow Radio Field Testing in the Washington DC, New York City, San Francisco, and Los Angeles (Long Beach) Radio Markets*”; Hammett & Edison Inc; January 6, 2004; at page 7-8.

²⁰ Ref: CBC Report ER-0605; Executive Summary; at page i

the (HD2) digital-only contour falls in approximately the same location as the FM station's 3 mV/m contour.

Considering all of the above, broadcasters implementing HD Radio services should anticipate that the point where HD1 services will blend to analog, and where HD2/HD3 service becomes quite unreliable, will generally occur at or inside their 1 mV/m analog contours. Inside the 3 mV/m contour the HD Radio service can be expected to be quite solid on mobile receivers, absent any very localized effects. Therefore, this analog contour level may be a better indicator of the true extent of reliable digital coverage to portables and mobiles, especially for multicast services that have no analog fall-back.

The CRC is currently conducting extensive laboratory tests of the HD Radio system, evaluating the transmission chain, receiver performance and interference issues. Results from these laboratory tests will be used to validate the HD Radio model in the CRC-COVLAB coverage prediction software. The field measurements collected near Toronto provide some indications of the performance. A comprehensive laboratory evaluation in a controlled environment is necessary for a complete validation of the model in CRC-COVLAB. Theoretical analyses of coverage duplication will be provided to the DRCG upon completion of the CRC laboratory tests and analyses.

7. Host Compatibility Issues

In its lab and field testing, the CBC evaluated the impact, on the "host" analog FM signal, of adding hybrid HD Radio carriers. The purpose was to determine if listeners using analog receivers would be likely to observe signal impairments due to the addition of the low-level digital carriers. Lab testing was carried out at various signal strengths, for both monophonic and stereophonic reception. Mobile reception in real-world conditions was simulated by employing a device that adds fading and multipath characteristics to the test signals (i.e. a channel simulator). Field observation of both CBLA-FM and CJBC-FM augmented data obtained in the lab.

With respect to lab results, and acknowledging that the number of test receivers was limited, the CBC report states that:

*"... some analog receivers will suffer degradation when a digital IBOC signal is injected on both sides of its host and that the impact will be greater for a stereo host than for a mono host."*²¹

On the other hand, the field tests in Toronto showed that:

*"...no impact of HD Radio on its analog FM host was detected inside the 54 dB μ V/m protected service contour."*²²

²¹ Ref: CBC Report ER-0605; at page 16

²² *ibid*; at page 26

Taken together, these results suggest that, in a quiet lab environment, HD Radio signals may degrade analog reception in a discernible way, but primarily where stereo services are concerned. Any negative impact is not as likely to be noticed by actual listeners, so long as the analog signals are being received reasonably well within the station's 0.5 mV/m protected service area.

With respect to reception outside the protected contour, the CBC report notes the following:

*“It should, however, be noted that, even though the service is not protected outside the 54 dBµV/m contour, most receivers are still able to achieve good or fair reception well beyond this contour (except in areas where high terrain shielding occurred), and that the addition of IBOC carriers degraded the perceived sound quality in those unprotected areas in such a manner that it became fair or poor in those same locations.”*²³

This factor could be a consideration for the CBC, which has a mandate to reach as many Canadians as possible. It could equally be of concern to commercial stations in the more sparsely-populated areas of the country (e.g. the Prairies and the North), where preservation of all coverage, regardless of location, is important.

For its part, the NRSC observed during its own compatibility tests that:

*“...the perceived audio quality, whether or not the IBOC sidebands are present, is highly dependent upon the type of programming being listened to. Specifically, “music” programming rated much higher (in the “good” range) than did “speech” programming (in the “poor” to “fair” range), under similar conditions. Overall, the small differences between ‘IBOC on’ and ‘IBOC off’ in Figure 9 indicate that the impact of the IBOC digital sidebands on the host analog signal is slight”.*²⁴

The technical evidence available to date suggests that HD Radio interference to analog FM services on host stations should not be a significant problem for broadcasters out to each station's 0.5 mV/m protected contour, except perhaps in situations where the analog signals are already weak. However, it should be noted that neither the CBC nor the NRSC tests were conducted using the “extended hybrid mode” of HD Radio, which has now been approved by the FCC for use in the US. As this mode allows the use of even more digital carriers within the FM channel, compatibility issues, including SCMO, should be reviewed prior to making a decision to authorize FM IBOC transmissions in Canada.

8. Adjacent-Channel Interference Issues

As described in Section 2, HD Radio digital carriers are added just outside the upper and lower outer edges of the radio channels occupied by the host analog FM station. Figure 2 of the CBC report illustrates the frequency overlap that occurs between two stations

²³ Ref: CBC Report ER-0605; at page 26; at page 26

²⁴ NRSC Report; “Evaluation of the iBiquity Digital Corporation IBOC System, Parts 1 FM IBOC;” November 29, 2001; at page 25

occupying 1st-adjacent channels.²⁵ The digital signals of the undesired HD Radio station fall within that portion of the desired analog station's spectrum to which ordinary FM radios will be tuned, thus presenting a potential for harmful interference. Unlike interference from another analog FM station, which usually will be heard as distorted audio in the background of the desired signal, digital interference will produce an audio "hash" in affected receivers.

In theory, the digital interference impact is mitigated by two factors: the power level of the digital signal is quite low and any two stations occupying 1st-adjacent channels are never allocated to the same market. This latter factor means that the interfering signal is most likely to be a problem in the outlying portions of the desired station's coverage area, where the latter's signal will be weaker.

The CBC report assesses the matter of interference to existing analog FM services due to the presence of HD Radio signals on a 1st-adjacent station, as well as the converse situation. While receivers were evaluated in the lab with respect to susceptibility to 1st-adjacent interference, the main effort was devoted to field work involving the HD Radio test station (CJBC-FM Toronto 90.3 MHz) and an analog-only station on 90.5 MHz (CBLA-FM-1 Crystal Beach ON).

Concerning the issue of interference to the desired HD Radio digital service (CJBC-FM) from an adjacent analog-only interferer (CBLA-FM-1), the CBC report states that its tests in the Toronto area showed that:

*"Apart from a very tiny area to the southeast of CJBC-FM's coverage (see map F-7116 in Appendix B), the tested configuration did not provide any other areas where interference to an HD Radio service from an analog station could be envisaged."*²⁶

The converse situation produced quite a different result. When the analog reception of CBLA-FM-1 was assessed in the presence of HD Radio signals on CJBC-FM, significant areas of interference were found within the protected service area of the Crystal Beach transmitter. The CBC report states the following in this regard:

*"Specifically considering CBLA-FM-1's case, subjective assessment of the sound quality was made before and after the addition of IBOC carriers on CJBC-FM. Comparison of the results can be made from looking at both maps F-7118 and F-7119 in Appendix I. Comparison of areas highlighted by Zone 4 clearly demonstrates that the signal from CBLA-FM-1 was degraded by 1 or 2 points on the ITU-R subjective assessment scale with the addition of IBOC carriers on CJBC-FM."*²⁷

It is important to note that several of these areas of digital interference to CBLA-FM-1 were located well within the protected contour of this station: in fact, one of the zones was within its 3 mV/m "city-grade" service area. The conclusion that the CBC draws from its tests is that the 1st-adjacent channel spacings currently specified in Industry Canada's FM

²⁵ Ref: CBC Engineering Report ER-0605; at page 5

²⁶ Ref: CBC Engineering Report ER-0605; at page 20

²⁷ *ibid*; at page 20

rules are “largely insufficient to adequately protect operating analog stations” if HD Radio digital carriers were to be added to analog stations.²⁸

These field results are consistent with those obtained during NRSC tests in the US. The NRSC’s report states:

*“These results indicate that under certain circumstances, for certain radios, the presence of the IBOC digital sidebands will have a noticeable effect on analog receiver audio quality. For example, the audio quality of the analog aftermarket auto radio, under moderate interference conditions, is reduced from the “good” range (with no IBOC present) to the “poor” range (with the IBOC digital sidebands present on a 1st-adjacent channel interferer)”.*²⁹

Although its 1st-adjacent interference test results were not particularly encouraging, the NRSC nevertheless concluded that “... the tradeoffs necessary for the adoption of FM IBOC are relatively minor.”³⁰ In other words, the overall benefits of allowing hybrid HD Radio would outweigh the negatives associated with any increase in 1st-adjacent interference to existing analog stations.

In the “Conclusions and Recommendations” section of its report, the NRSC states:

*“...listeners should not perceive an impact on the analog host signal, nor on the analog signals on carriers that are either co-channel or 2nd-adjacent channel with respect to an IBOC signal. With respect to carriers that are located 1st-adjacent to an IBOC signal, listeners within the protected contour should not perceive an impact, but a limited number of listeners may perceive an impact outside of the protected contour under certain conditions.”*³¹

It is significant that, in the US context, “outside of the protected contour” often means beyond the 1 mV/m service area. In Canada, the referenced interference could therefore occur between the 1 mV/m and 0.5 mV/m contours. To a considerable extent, this conclusion is supported by the CBC tests conducted within the CBLA-FM-1 Crystal Beach service area.

In summary, it appears that, with any wide-scale implementation of HD Radio in Canada, FM broadcasters could expect to find interference within their current protected contours from 1st-adjacent HD Radio digital services. Although this might be corrected by increasing the spacings between related stations, this does not seem very practical, as it would involve a considerable amount of re-siting for existing FM stations. Further theoretical analyses of hybrid HD Radio digital interference to analog FM will be provided to the DRCG upon completion of the CRC laboratory tests and analyses mentioned previously.

²⁸ Ref: CBC Engineering Report ER-0605; at page 26

²⁹ NRSC Report; “Evaluation of the iBiquity Digital Corporation IBOC System, Parts 1 FM IBOC;” November 29, 2001; at page 26; at page 26

³⁰ *ibid*; at page 9

³¹ *ibid*; at page 9

9. Practical HD Radio Implementation Considerations

If HD radio were to become licensable in Canada, FM broadcasters would need to consider the practical implications of implementing this technology, as well as its cost. One advantage of being able to observe the current roll-out of HD Radio in the US is that Canada can learn from actual experience south of the border. Moreover, the knowledge gained by the CBC in implementing the Toronto test facilities can be drawn upon.

With respect to cost issues, the CBC makes the following statement in its technology trial report:

“HD radio basically relies on a digital signal that is 100 times less powerful than that of the host FM station on which the HD radio signal is overlaid. This leads one to believe that HD radio is inexpensive to implement. In practice, this is not the case. As we learned from our colleagues at National Public Radio (NPR), implementing FM HD radio requires a substantial investment.”³²

Broadcasters may also take guidance on this matter from iBiquity Digital Corporation whose President and CEO, Robert Struble, is quoted as saying,

*“The average [cost] estimate in the U.S. is about \$100,000. That could be as low as \$25,000 or as high as \$200,000”.*³³

Appendix 2 of this report is a narrative outlining the various technical methods of implementing HD Radio at existing FM analog transmitter sites. Included are the four most common approaches, known as “low-level combining”, “high-level combining”, “split-level combining” and “separate antennas”. The first three involve adding a new DRB signal to an existing FM antenna. The latter method requires the addition of either a separate DRB-only antenna on the tower or else the replacement of the existing FM antenna with a new model that has FM and DRB radiating elements intertwined within the same tower space.

For a variety of reasons, explained more fully in Appendix 2, adding HD Radio service to an existing antenna is highly inefficient. As can be seen from Table 1 in the Appendix, the amount of waste heat that must be eliminated from the transmitter building when operating with any of the three combining modes would more than double. Moreover, combiner systems of this type also reduce the analog station’s power by 10%. This can sometimes be offset by cranking up the analog power, assuming the older transmitter is not already running flat out.

While the “separate antennas” methodology is the most efficient way of introducing HD Radio, it may require additional capital investment in antennas and/or upgrades to the supporting towers. Moreover, it is necessary to ensure that the azimuth and elevation radiation patterns of the digital and analog antennas are very similar; otherwise, the station

³² Ref: “*HD Radio Technology Trial Project Report*”; CBC Technology; April 4, 2007; at page 7 (See Appendix 1 for detailed reference and URL)

³³ Ref: “*Digital Radio State of the Industry*”; Broadcast Dialogue magazine; April 2007; at page 13

may not be able to guarantee that the required 1:100 power ratio between the digital signal and the analog signal is maintained at all receiving locations within the service area. Should this requirement not be met, the result could be interference to other stations or to the host FM station.

It is also a fact that many Canadian FM stations, especially those in the major markets, operate using shared transmitter buildings, towers and antennas. Complex shared antenna systems, such as those implemented at the CN Tower in Toronto and Camp Fortune in Ottawa, generally employ narrow-band combiners. It would present great technical challenges if all the FM stations sharing the facility were to decide that they each must add a digital signal to their present analog systems.

The CBC's Toronto experience also demonstrated that great care must be taken in processing audio and dealing with the fact that the simulcast (HD1) analog signal must be delayed before being transmitted. If this is not done, listeners to HD1 services can notice substantial variations when their receivers switch back and forth between digital and analog. (i.e. when the blending function activates during digital signal failures). The CBC suggests that separate audio processing may be required for the analog and digital feeds.³⁴

10. Related Regulatory and Other Issues

If radio broadcasters were to make a strategic decision to proceed with the implementation of in-band digital services in Canada, there are a number of related regulatory issues that would need to be resolved.

IC Authorization:

As with any broadcast technology that involves the use of radio spectrum, Industry Canada would need to develop a transmission standard for any form of in-band DRB that might be selected for use in this country. The process would likely be similar to that followed when the Eureka 147/DAB standard was selected. Broadcasters would first make representations to Industry Canada recommending adoption of the selected standard. Assuming the Department finds the proposal acceptable from the point of view of spectrum utilization, it would prepare appropriate documents describing the selected standard, any required operating rules, as well as the necessary application procedures. These would then be published for public comments, perhaps simultaneously with them being brought into force on a provisional basis.

Wide-scale implementation of in-band digital services would mean the creation of many new radiofrequency signals that would operate in channels already used by existing analog services. Consequently, it would be vital for analog stations to have access to an effective means of resolving any concomitant interference complaints. This would be necessary because in-band DRB has the potential to produce a negative financial impact on affected analog stations on the very first day that an interfering neighbouring station activates its

³⁴ Ref: "HD Radio Technology Trial Project Report"; CBC Technology; April 4, 2007; at page 12

digital service. The interference-resolution mechanisms might include specific rules and regulations that would be imposed on incoming digital services. In addition (or perhaps alternatively), Industry Canada might implement a dispute resolution mechanism that existing stations could invoke when necessary.

CRTC Authorizations

In its revised digital radio licensing policy, the CRTC says with respect to in-band services:

“Accordingly, if the Department authorizes IBOC technology for the AM and/or FM bands under the Radiocommunication Act, the Commission would be prepared to authorize services using this technology under the Act. An expedited process would be adopted (sic) for stations that propose to transmit a digital simulcast of their analog service.”³⁵

While the Commission promises an “expedited process”, broadcasters should probably not assume that this would mean blanket permission by the CRTC to implement in-band DRB, even when they propose to use their digital signals only to simulcast their analog program content.

It remains unclear from the Commission’s Public Notice how it would deal with proposals to implement additional multicast programming services within an HD Radio multiplex (i.e. HD2/HD3). Some guidance may be taken from the section dealing with new non-simulcast services added to L-Band multiplexes, where the CRTC says *“Each L-band service will require its own licence”*.³⁶ The CRTC could also decide to apply its current SCMO authorization framework to the operation of multicast HD Radio services. Presumably this and other issues would be addressed at a future date, since the policy announcement also says:

“The Commission will adopt a specific framework for IBOC and other technologies for digital radio if and when IBOC and other technologies related to digital radio are adopted in Canada”.³⁷

Proprietary Issues Related to the HD Radio Standard

Section 2, which describes the iBiquity HD Radio system, notes that this technology has certain associated proprietary rights. If broadcasters were to select HD Radio as the industry’s chosen in-band technology, it would mean designating a national broadcasting standard that is not fully described technically. The main consequence of this is that iBiquity retains control over who can produce receiving and transmitting equipment that carries the HD Radio trademark and makes use of its software. This issue may have to be considered by Industry Canada should it decide to move ahead with standardization, since it may be the first time that such an arrangement would be applied to a broadcasting

³⁵ Ref: Broadcasting Public Notice CRTC 2006-160, 15 December 2006; para 56

³⁶ Ref: Broadcasting Public Notice CRTC 2006-160, 15 December 2006; at para 43

³⁷ *ibid* at para 35

standard in this country. Nevertheless, it may not be found to be a significant obstacle, so long as other in-band systems (e.g. DRM) are also eligible for consideration as standards and none are designated as mandatory.

The payment of licensing fees to iBiquity for the right to transmit HD Radio is another factor for consideration.³⁸ US broadcasters implementing HD1 (simulcast) services are obliged to pay a one-time royalty fee directly to iBiquity. This fee is set at \$US10,000 if paid before 30 June 2007 and reaches \$US25,000 if paid after 30 June 2008.³⁹ For ancillary audio channels (HD2/HD3), the licence fee is set at 3% of annual net revenues derived from each such service or \$US1,000, whichever is the larger. Auxiliary data services pay a fee of 3% of net revenue, calculated quarterly.

Non-US broadcasters have been advised that they will be charged the one-time royalty fee for implementing simulcast (HD1) services; however, these fees will not be remitted directly to iBiquity. Rather, they will be built into the equipment prices charged by manufacturers for products shipped to non-US stations. Likewise, no recurring fees will be charged for implementing HD2/HD3 ancillary services because the additional “importer” equipment required to generate these multicast signals will also be priced to include a built-in royalty fee. As for ancillary data services, iBiquity has advised non-US broadcasters that additional fees may be charged in the future for “advanced applications programs and specialized data services”, which have yet to be developed.⁴⁰

What this means is that all broadcasters will pay the one-time royalty to iBiquity for the implementation of simulcast digital services. In the US, the recurring fee for multicast audio channels will be paid only when stations make money from these services, since the rate is set at a percentage of net revenue. However, non-US stations will pay an up-front one-time royalty, whether their ancillary audio services ever make money or not.

11. Conclusions and Recommendations

In this report, the DRCG provides an initial technical assessment of the functional strengths and weaknesses of iBiquity’s HD Radio IBOC DRB system, as it applies to FM band operations. Specifically, an effort has been made to provide broadcasters with guidance about what to expect in the way of performance in the event that this technology were to be introduced into the Canadian broadcasting system.

The principal sources of information for this report have been the CBCs’ 2006 field/lab tests and technology trials, as well as the technical studies undertaken by the NRSC in 2003-2004. While there were significant similarities in the test results obtained by the

³⁸ Ref.: iBiquity website at http://www.ibiquity.com/i/Licensing_Fact_Sheet2007.pdf

³⁹ To encourage early adoption by US multi-station owners, iBiquity has recently (Mar 2007) set a cap of \$US10,000 per station on the one-time royalties payable by groups, so long as certain early implementation commitments are made.

⁴⁰ Ref: E-mail communication to the DRCG from Perry Priestley, Director, International Broadcast Business Development; iBiquity Digital Corporation; 2006-11-13

CBC and the NRSC in some cases, there is also some divergence in the way these results have been interpreted. This is not unreasonable, since the FM band operating environments in Canada and the USA, while quite similar on the surface, have certain important differences that need to be taken into account.

Specifically, US broadcasters have taken the view that, while in-band DRB may degrade existing FM analog services, such impact would be tolerable. This is because FM services in most large US markets are already interference-limited to a greater extent than currently occurs in Canada. Moreover, they say, the long-term benefit of introducing digital services in the FM band outweighs the near-term negative impact.

Adding new in-band DRB is therefore less likely to become a matter of listener irritation than would be the case in Canada, where broadcasters have experienced wider interference-free service areas since the inception of FM broadcasting. In the Canadian context, the DRCG's analysis show that there are two key areas of concern:

Duplication of analog service areas: Canadian test results indicate that broadcasters should not expect HD Radio listeners to be able to receive reliable digital services beyond the official 1 mV/m FM analog service contour. In many cases, reliable reception will in fact be limited to about the official 3 mV/m (city-grade) FM contour, especially when listeners are using typical home or mobile receivers with antennas about 1.5- 2 m. above ground. Although not specifically evaluated in the CBC tests, reliable indoor reception is believed to be even more limited, unless an outdoor antenna is used.

Interference to 1st-adjacent analog services: The DRCG's evaluations also indicate that a wide-scale implementation of HD Radio has a considerable potential to create new zones of interference, to analog FM stations operating on 1st-adjacent frequencies, in areas situated between the 1 mV/m and 0.5 mV/m contours of these existing stations. This would be particularly a risk in spectrally-congested radio markets.

In both of the above situations, the impact on commercial stations in US markets may be tolerable, given that protected commercial analog FM service areas often do not extend beyond the 1 mV/m contour in any event.

In a number of instances, the CBC reports indicate that the limited scope of its HD Radio testing, as well as time constraints, may have affected the results it obtained. The Corporation has suggested that more work should be done in some areas, to better define the scope of the problems and perhaps find solutions.

The DRCG considers that, based on the evidence currently in hand, it would be risky for Canadian broadcasters to proceed at this time with an unrestricted roll-out of HD Radio services in the FM band, in the manner implemented in the US. At this time, there appears to be little down-side in taking more time to evaluate in-band digital radio technologies, given that:

- HD Radio has been implemented by only 10% of US FM stations to date; and,
- there is no ground-swell of radio listener interest in this technology so far; and,
- the lack of inexpensive receivers, as well as unique new programming services, continues to make it difficult to market HD Radio to the public; and,
- there is no evidence that Canadian radio listeners are being lost to US terrestrial stations that have implemented this technology.

Considering all of the evidence presented in this report, the DRCG makes the following recommendations with respect to the Canadian FM-band environment:

- (1) **As announced in its revised radio policy, the CRTC should refrain from licensing permanent HD Radio or other in-band DRB operations until Industry Canada has established appropriate technical rules.**
- (2) **Before regulatory action is taken to authorize permanent in-band DRB facilities, Industry Canada should:**
 - **complete a detailed technical evaluation of in-band technologies, including theoretical studies by CRC as well as additional co-operative field assessments in spectrum-congested markets; and,**
 - **establish clear mitigation measures to deal with harmful interference, if caused by digital operations within the protected service areas of existing stations.**
- (3) **Broadcasters should continue monitoring in-band DRB developments, especially in the USA, to determine when it may be appropriate to introduce this technology in Canada, taking into account the following indicators:**
 - **the number of affordable portable and home in-band DRB receivers that are being purchased by the public; and**
 - **the number of in-band DRB receivers that are being purchased as OEM equipment in new vehicles in North America; and**
 - **the tuning levels for in-band DRB services (both simulcast and multicast) that are being achieved in US radio markets.**

In concluding this report, the DRCG wishes to thank all those who have contributed to planning and carrying out this evaluation project. Special thanks are due to the CBC, which early on expressed a willingness to share with the DRCG the results of its planned HD Radio evaluations, and to the CRC. Both of these organizations provided considerable personnel and financial resources over the past 12 months. Thanks also go to DRRI, which provided a financial contribution to offset some of the costs associated with this work and to Industry Canada, which authorized the special transmissions required to carry out the field work.

APPENDIX 1

LIST OF CBC REPORT REFERENCES

1. F. O. Gauthier, P.Eng, P. Marcoux, P. Eng and C. Rousseau, Jr. Eng. “*IBOC Field and Lab Trial Results from Toronto, ON*”, Report ER-0605, Delivery Systems and Spectrum Engineering, Strategy and Planning, CBC Technologies, CBC/Radio-Canada, Montréal, March 2007.

NB: This report can be obtained at this URL:

ftp://spdssepub:public@ftp03.cbc.ca/strat&plan/DSSE/Public/CBC_ER-0605_IBOC_Field_and_lab_trial/

[Cautionary note: this file is 42.8MB in size]

2. G. Bouchard, A. Caruso, P.Eng, and F. Conway, P.Eng; “*HD Radio Technology Trial - Project Report*”; New Broadcast Technologies, Strategy & Planning; CBC Technologies, CBC/Radio-Canada, Montréal, April 4, 2007.

NB: This report can be obtained at this URL:

[ftp://cbcspp:\\$public@ftp03.cbc.ca/strat&plan/nbt/Public/HD_radio_report/HD Radio Technology Trial Report_FINAL VERSION.doc](ftp://cbcspp:$public@ftp03.cbc.ca/strat&plan/nbt/Public/HD_radio_report/HD Radio Technology Trial Report_FINAL VERSION.doc)

APPENDIX 2

IBOC Implementation Issues

IBOC implementation technique

Adding an IBOC signal to any host station may sound like a trivial exercise, however the spectral proximity of both signals prohibits the use of tuned combiners, which would be an efficient signal injection vehicle.

The requirement for FM-to-IBOC isolation is also somewhat difficult to achieve in practice because of the power ratio between FM and IBOC (100:1). In a combiner that has to deal with a 1:1 power combining ratio, a 26 dB isolation seems to be fine. (e.g. two 1 kW transmitters combined together would each receive 2.5 watts of reflected power). With IBOC, a 1 kW FM signal would be combined with a 10W IBOC signal. With the same 26 dB isolation the 10 W IBOC transmitter would receive 2.5W of reflected power from the FM host, so an isolation figure in the 40 dB range would be required for such applications.

There are a few techniques used to combine FM and IBOC signals:

Low level combining

Low-level combining relies essentially on a common amplification technique which means that both the host FM and the IBOC signals are amplified in the same Power Amplifier (PA). This method requires very good linearity from the PA part. Any non-linearity will result in intermodulation products that are likely to interfere with adjacent FM stations. Most PA's cannot handle common mode amplification at rated output power: they have to be operated in the most linear portion of their transfer curve which results in a substantial back-off (around 6-10 dB), However some advanced pre-distortion and linearization techniques can be used to alleviate the amount of back-off that has to be used to meet intermod specifications (4 to 6 dB).

Fig. 1: Low level combining option

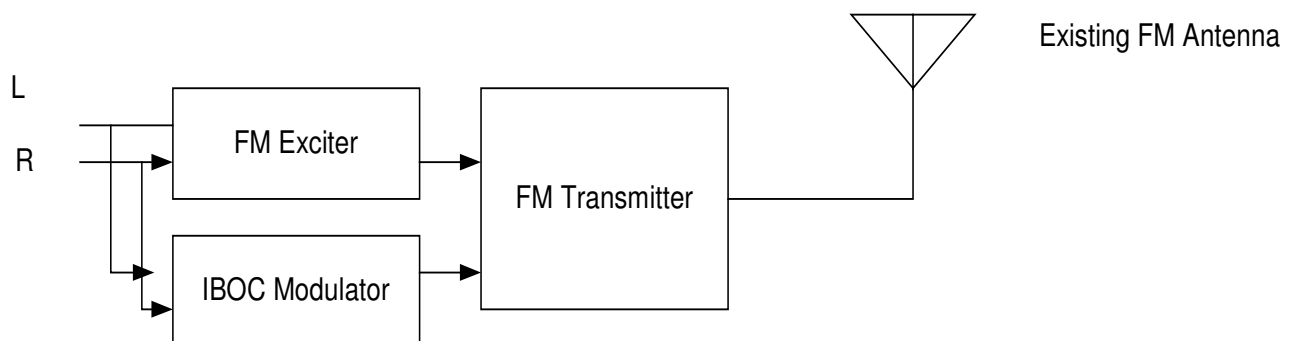

As IBOC adds about 1 % to the total channel power, its power contribution is negligible so the power rating of the antenna is normally not an issue, However IBOC requires about 400 kHz more bandwidth than conventional FM, so antenna system frequency

response may become problematic, especially in transmitter sites using narrow-tuned combiners.

Low level combining is unlikely to be implementable in an existing transmitter, A new transmitter optimized for the purpose is generally a more cost efficient solution.

High Level Combining

High Level combining is based on the use of distinct power amplifiers for the Host FM and the IBOC signals.

Fig. 2: High level combining option

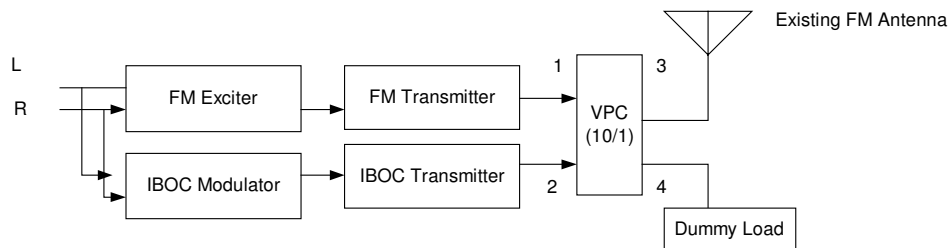

Both signals are combined together at the amplifier outputs before hitting the antenna, This technique uses an IBOC Power injector which is basically an inverted directional coupler, Not being a broadband device, it is not frequency selective at the FM band scale, However its power ratio is selected to minimize the loss on the host path, (port 1 to 3) typically 0.5 dB (this is chosen so the host can still keep its original FM coverage using the existing transmitter). However such an injector offers a loss of about 10 dB on the IBOC path (port 2 to 3). This process means that 90 % of the IBOC power gets dissipated in Port 4 that is connected to a dummy load. Due to the fact that the IBOC injection level is 1%, the PA required for the IBOC remains much smaller than the analog host, since 10 times 1% is still only 10%.

Although this implementation sounds like very inefficient, it is used because it is especially practical when IBOC is retrofitted in an existing FM station.

Split level combining

Split level combining is a technique that uses only a part of the power amplifier to carry IBOC, using common mode amplification. Most of the modules are fed with the FM Host signal at full rated power while a few modules are carrying both IBOC & FM with a substantial power back-off. Therefore the resulting composite back-off of the entire transmitter is mitigated by the fact that most of the modules are running at full power. This is usually the most efficient scheme; however, most of the time it requires a new transmitter. and is therefore best done when the FM transmitter is being replaced anyway.

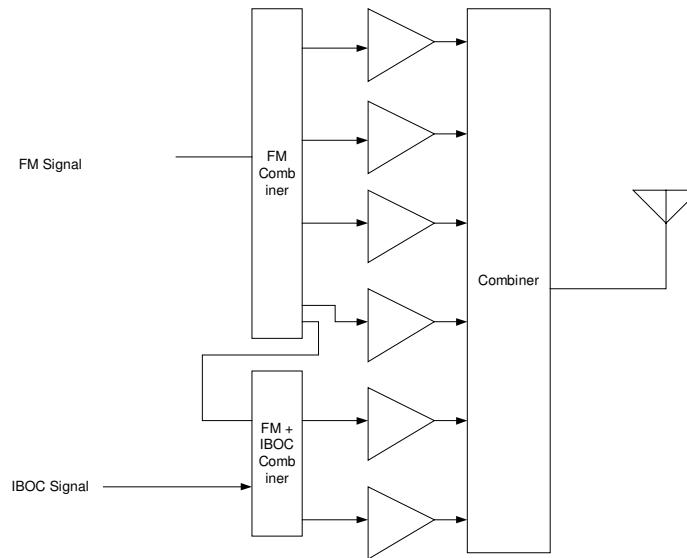
Fig. 3: Split level combining option**Separate antennas**

Separate antennas is a technique by which 2 distinct transmitters and 2 discrete antennas are used to carry both FM and IBOC signals. This technique has the advantages of requiring very little IBOC transmitter power and imposing no additional loss to the host transmitter. However, its application is cumbersome, as both antennas have to have similar radiation patterns (vertical and horizontal) and they also have to be installed very close in aperture so their coverage is more or less equivalent.

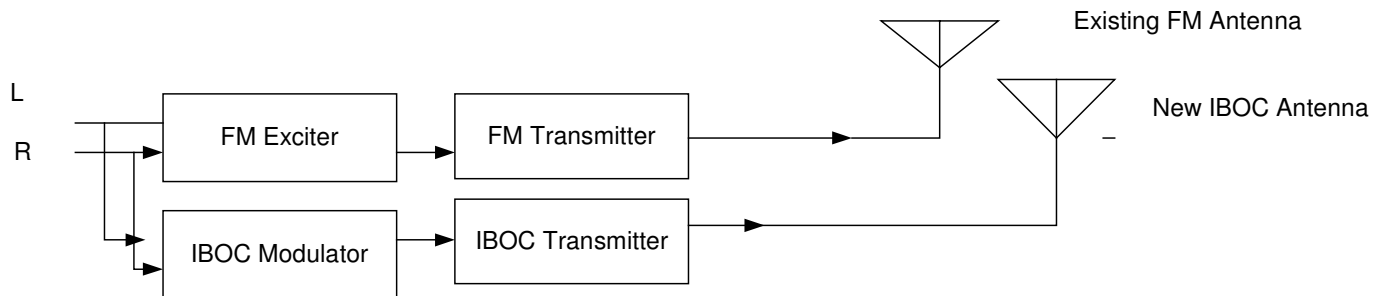
Fig. 4: Separate antenna option

The IBOC antenna generally is located in the same aperture as the FM antenna, (interleaved antenna) which probably means that this technique is viable for antennas implemented in full wavelength spacing, The isolation between the antennas is achieved by arranging for the IBOC antenna to operate in the opposite polarization.

A separate antenna is a viable alternative in the specific case where the tower has the necessary spare aperture, spare wind load and spare weight capacity. From the energy consumption standpoint it is the most efficient technique.

Comparison of combining techniques

Table 1. Typical case where a 5 kW host FM station is retrofitted with IBOC

Technique	FM power (kW)	IBOC power (W)	Required FM TX Power (kW)	Required IBOC TX power (W)	Heat generated (kW)				Efficiency (%)		
					By reject load	By FM Transmitter	By IBOC Transmitter	Total	FM	IBOC	Overall
Reference Solid state transmitter with no IBOC	5	0	5	0	0	2.9	N.A.	2.9	63	N.A	63
Low Level combining	5	50	8.2	0	0	6.11	N.A.	6.11	45	N.A.	45.4
High Level combining	5	50	5.556	500	1.006	4.26	0.96	5.92	53	2.9	46.2
Split level combining	5	50	5	0	0.778	5.22	0.1	5.32	49	N.A.	49
Separate antennas	5	50	5	50	0	2.9	0.166	3.066	63	30	62.8

Source: Harris Corp. calculators.

Conclusion: In some of these cases, the injection of 50W of IBOC power leads to the generation of 2 to 3kW of extra heat in the room with ancillary impact on HVAC systems. None of these combining techniques are trivial to implement, the choice will be driven by the infrastructure in place.

Actual implementation at First Canadian Place (Toronto ON):

This site was equipped with 2 solid state FM transmitters:

- CBL-FM (English radio one, (mono service)) had a 20 kW Nautel unit
- CJBC-FM (French espace musique (stereo service)) had a 2 kW Harris unit.

As both units were existing transmitters, high-level combining was the only viable combining strategy.

FM IBOC injectors from Shively Labs were chosen for this project, the latter features an insertion loss of 0.35 dB in the FM port and of 10 dB in the digital port.

In order to meet the recommended injection level of 1 % of the FM Host power, the following IBOC power had to be used:

Table 2: IBOC power requirements

HD Radio project combiner set-up						
Station Host station	FM transmitter Power kW	Effective FM Power (after combiner)	Required IBOC power Watts	Injector Loss (dB)	Required IBOC transmitter power (watts)	Effective FM Power kW
CJBC	2	1.85	18.5	10	185	1.845
CBL-FM	20	18.45	185	10	1.85	18.45

CJBC was supplemented by a BE FMI-73 (courtesy of Industry Canada) capable of 250W IBOC power . CBL-FM was supplemented by a Nautel V10 (courtesy of Nautel) capable of 3.5 kW IBOC power

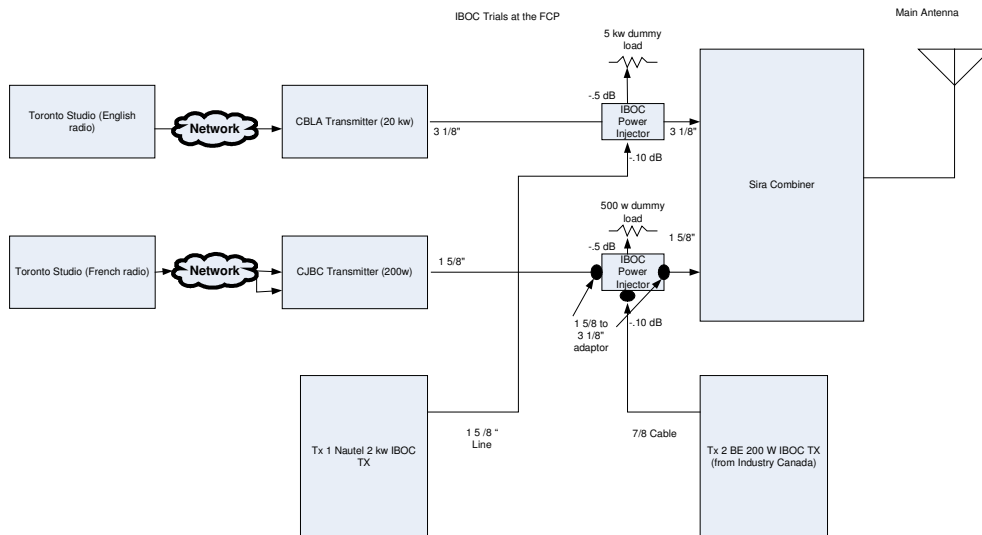

Fig 5. HD Radio project RF functional

Implementation issues:**Heat:**

Just for CBL-FM the supplementary heat dissipation was very significant:

Power dissipated in the reject load:

90 % of the Digital Power (1.85 X 0.9) = 1.665 kW +
+ 10 % of the FM host power 10% of 20 kW = 2 kW

Power dissipated by the HD Radio transmitter:

1.85 kW at an efficiency of 30 % = 6.16 kW (the transmitter was not running at rated IBOC power which result in a lower efficiency figure)

Power dissipated by the RF path:

Supplementary TX line loss = 0.15 dB + IBOC injector loss 0.35 dB + 0.5 dB (about 10.8 % power reduction)

2.17 kW

At total of 12 kW of extra heat was dissipated in the room.

Audio distribution, delays & processing**HD Radio requirement:**

HD Radio requires 2 audio feeds: one real time feed, one delayed feed. (This second feed is a delay-compensated feed required to supply the analog FM transmitter with the same processing delay that the digital uses). Most HD Radio excitors are equipped with an AES EBU delay line for this purpose.

Audio processing and stereo transmission

Most stereo transmitters are using an audio processor to process the baseband audio signal and often the broadcaster relies on the latter to create the composite stereo coded audio signal that is used to feed the FM transmitter.

However the HD Radio equipment (audio delay line) doesn't support this format. For this project, two separate audio processors had to be used (one for the FM analog, one for the HD Radio feed). The difficulty lies in getting the two processors to compress in a similar manner so that the digital-to-analog blend sounds reasonably seamless.

G. Bouchard
New Broadcast Technologies,
Strategy & Planning; CBC Technologies,
CBC/Radio-Canada, Montréal
2007-04-16

APPENDIX 3

DRCG Members - 2007

Last_Name	First_name	Organization	City	
1	Bergin	Gerald	CRTC	Gatineau
2	Bouchard	Guy	CBC	Montreal
3	Camire	Doris	CRC	Ottawa
4	Carr	Andre	CRC	Ottawa
5	Caron	Bernard	CRC	Ottawa
6	Caruso	Tony	CBC	Montreal
7	Daigle	Martin	CRTC	Ottawa
8	Gallant	Josette	CRTC	Ottawa
9	Gauthier	Francois	CBC	Montreal
10	Haydu	David	CHUM Radio	Toronto
11	Henke	Gord	D.E.M.Allen & Assoc	Winnipeg
12	Hoepfner	Jack	Corus Radio	Winnipeg
13	Jones	Harrie	CHUM Radio	Ottawa
14	Latreille	Robert	Radio Astral	Montreal
15	Lefebvre	Francois	CRC	Ottawa
16	Lennox	Wally	Standard	Toronto
17	MacMillan	Don	Industry Canada	Ottawa
18	Marcoux	Pascal	CBC	Montreal
19	McLarnon	Barry	Consultant	Ottawa
20	Mimis	Vassilios	Industry Canada	Ottawa
21	Nesbitt	Kirk	Rogers Broadcasting	Toronto
22	Stacey	Wayne	CAB / Stacey & Assoc	Ottawa
23	Thibault	Louis	CRC	Ottawa
24	Voyer	Rene	CRC	Ottawa